

## Specification of 24V/48V/110V/220V/200Amp Float and Boost Battery Charger

AC Input with wide operational Range		
Nominal Voltage	415V AC, $\pm 10\%$ 3 or 4 wire as per customer requirement	
Frequency	50Hz $\pm 5\%$	
DC output with an adjustable Range		
Voltage	24V /48V /110V /220V	
Current	Range up to 200A as per customer requirement	
Ripple	< 3%RMS	
Regulation	Within $\pm 1\%$ according to variation of input AC main supply	
Rectifier Bridge	Full wave half controlled (or) full wave full controlled	
Efficiency	Better than 80% at full load @ nominal AC input	
Noise Level	<65dBA for natural cooling and 75dBA for forced cooling	
Float Charger		
Float Voltage Adjustment	80% to 115% of nominal or as per customer's specific requirement	
Current Adjustment	As per customer requirement	
Boost Charger		
Boost Voltage Adjustment	80% to 135% of nominal or as per customer's specific requirement	
Current Adjustment	As per customer requirement	
General		
Configuration	Float and Boost Battery Charger (Fig 1)	
Protection	AC input circuit breaker DC output circuit breaker Battery input fuses Charger over load Battery charging current limit Short circuit protection Built in DCDB as per customer requirement	
Meters	Analog / Digital meters (As per customer requirement)	
Indication & Alarms (Indications through either bright led's or multi point facia display)	Indication	Indication & Alarms
	Input on Charger on float Charger on Boost	DC over voltage AC supply fail Charger fail Battery , Isolator open Rectifier Fuse fail DC earth fault DC Filter (capacitor ) fuse Failure Charger fuse /MCB trip
Switches & Control	Float voltage POT Boost voltage POT Charger ON / OFF switch Manual(Float or Boost) / Auto select switch	
Battery compatible with	VRLA Battery / Non -VRLA Battery	
Paint	RAL 7035 or as per customer requirements	
Dimensions	As per industrial standards or as per customer specific requirements	
Cooling	Natural or Forced (As per customer requirement)	
Temperature range of operation	0 deg C to 45 deg C	
Cable entry	Bottom entry or Top entry on customer request	
Applicable Standard	IEC 146 / IS 4540	

Storage Temperature	-30 to 70 deg C
Humidity	0 to 95 % RH Non condensing
Altitude	Up to 1000 MSL
Routine Test (Conducted at Waves Electronics Pvt. Ltd generally conforming to IEC 146 / IS 4540)	Visual & Dimensional check Insulation resistance test High Voltage test Measurement of Voltage Regulation Annunciation checks Measurement of Ripple Charger Functional checks Heat run test (8 hrs) on customer request Efficiency & Power factor measurements
Options	Frequency : 60Hz 50°C Ambient Temperature Redundant cooling fans Computer connectivity : RS – 485 LCD Display with keyboard for setting parameters of charger DC Distribution Board

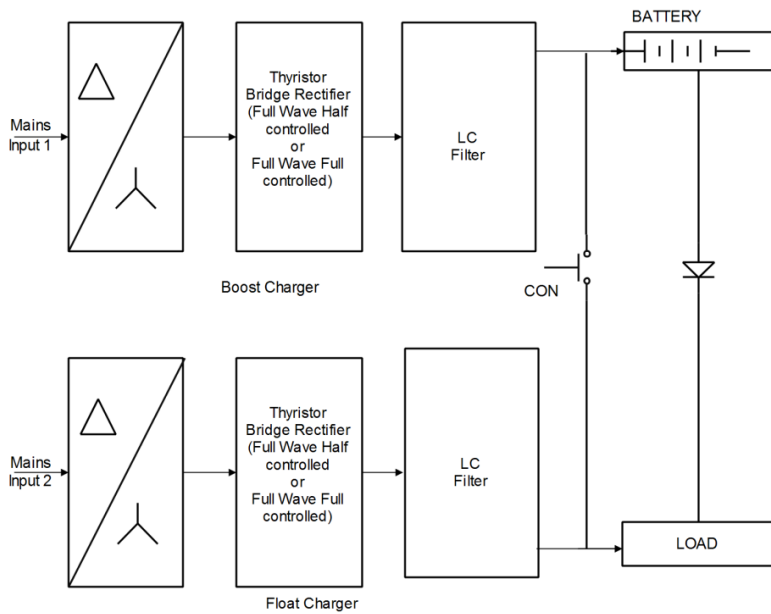

Input 1	Input 2	FC	BC	CON	BATTERY	LOAD
On	On	On	Off	Close	Float	FC
On	On	On	On	Open	Boost	FC
Off	Off	Off	Off	Close	Discharge	Battery
On	On	Fail	Cut Off	Close	Discharge	Battery
Off	On	On	Off	Close	FC	FC

FC : Float Charger    CON : contactor  
BC: Boost Charger

Fig 1 :Float and Boost Battery Charger